

MODEL

KP



INSTALLATION, OPERATION & MAINTENANCE MANUAL

KP Knife Gate Valve

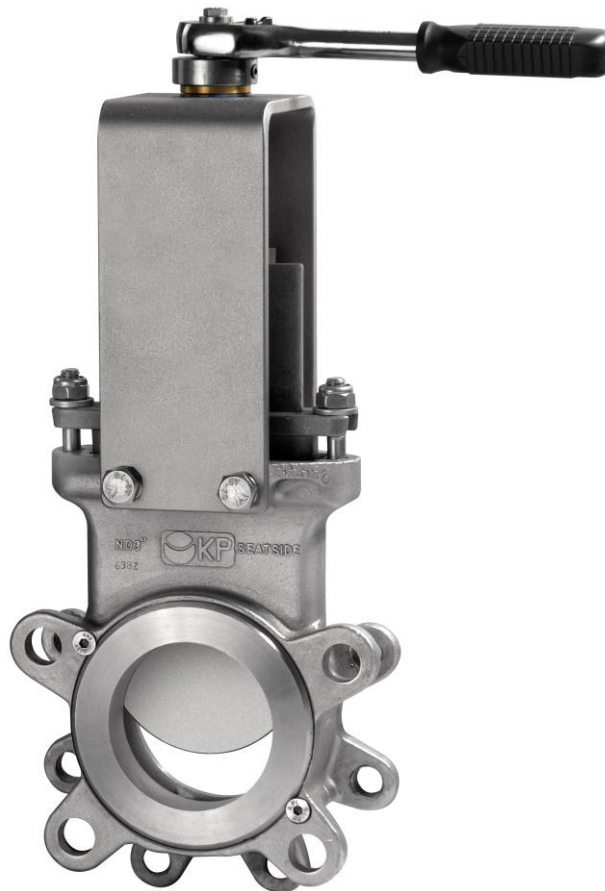

INSTALLATION, OPERATION & MAINTENANCE MANUAL

KP Knife Gate Valve

- 0. INTRODUCTION
- 1. HANDLING
- 2. INSTALLATION
- 3. ACTUATORS
 - 3.1. Wrench
- 4. MAINTENANCE
 - 4.1. Gland packing replacement
 - 4.2. Seal replacement
 - 4.3. Lubrication
- 5. STORAGE
- 6. ENVIRONMENTAL CONSIDERATIONS
- 7. PARTS LIST & DRAWING

0. INTRODUCTION

The KP model knife gate is an isolation wafer valve for a transmitter on a tank for which a short face to face is required. The valve is mounted directly on the tank and the transmitter can be dismantled without draining the tank.

The KP valve complies with the following European directives:

- Machinery Directive

When applicable it can also comply with the following additional directives:

- Pressure Equipment Directive
- Potentially Explosive Atmospheres (ATEX)

It is the user's liability to clearly inform the maximum working conditions (PS, TS), medium (gas or liquid), dangerousness group (1 or 2) and if the fluid is unstable to properly classify the valve according to the PED directive.

ORBINOX offers, supplies and certifies valves according to the information received from the customer. The customer is liable to make sure this information is accurate and according to specific working conditions requirements where the valve will be installed.

**For EU Directives and other Certificates, please see the document:
Directives & Certificates Compliance - Knife Gate Valves - IOM**

1. HANDLING

The valves are packed according to the appropriate transport standards. If you receive the packing damaged, please inform the transport company in writing and contact your ORBINOX representative.



When handling an ORBINOX valve please pay attention to the following points:

- **DO NOT ATTACH LIFTING GEAR TO THE VALVE ACTUATORS OR GATE GUARDS.** They are not designed to bear the weight and could easily be damaged.
- **DO NOT LIFT THE VALVE BY THE VALVE BORE.**
This can cause damage to the seating surfaces and seals.
- Check that selected lifting gear is rated to carry the weight of the valve. The valve can be handled using eyebolts, soft straps or slings.
- **EYEBOLTS:** make sure the eyebolts have the same thread as the bolt holes and they are all well secured. Ideally when using lifting gear to move an ORBINOX valve, it should be supported by two or more eyebolts screwed into the tapped fixing holes in the valve body.
- **SOFT STRAPS:** with the valve in the closed position, the straps should be placed between the gland area and the bore such that the valve is balanced.

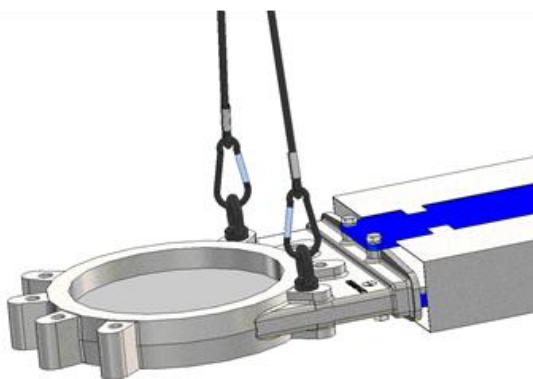

Fig. 1 Handling with eyebolts

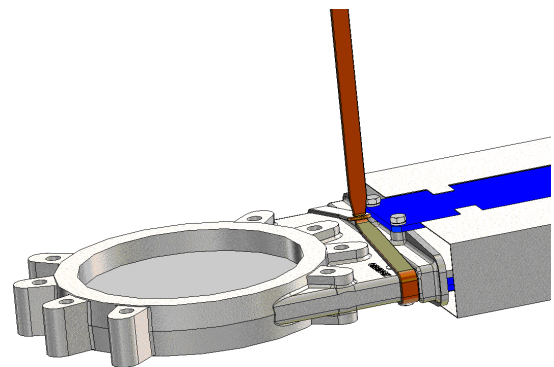

Fig. 2 Handling with soft straps

2. INSTALLATION

**For EU Directives and other Certificates, please see the document:
Directives & Certificates Compliance - Knife Gate Valves - IOM**



In order to avoid personal injury or damage to property when handling and installing the valve, it is important to observe the following warnings:

- It is the User's responsibility to verify compatibility of valve parts materials with the internal fluid
- Qualified and trained personnel must carry out the handling and maintenance of the valve
- Use suitable Individual Protection Equipment (IPE) (gloves, safety footwear...)
- Disconnect all lines affecting the valve and put up a notice notifying that work is being carried out on the valve
- Isolate the valve completely from the process
- Release process pressure
- Drain the fluid from the valve

Before installation, inspect the valve body and components for any damage that may have occurred during shipping or storage. Make sure the internal cavities within the valve body are clean. Inspect the pipeline and mating flanges, making sure the pipe is free of foreign material and that the flanges are clean.

The valve should be installed with the words "SEAT SIDE" (marked on the valve body) in the tank side. Installation and the correct orientation with respect to the direction of the flow is the responsibility of the user.

The following table shows recommended torque values for the valve fixing bolts and the maximum depth (T) of blind tapped holes:

DN (mm)	T (mm)	PN-10 (EN 1092-1)	CL150 (ASME B16.5/B16.47 Series A)	Torque (N.m)
80	11	M16	5/8" - 11 UNC	70Nm

Select the recommended torque based on bolt size for other flange drilling patterns.
Make sure that cross-pattern tightening sequence is always followed.

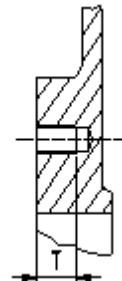

The valve can be mounted in any position with regard to the tank. However, it is advisable to place it vertically in the tank (A) if the installation allows it. (Please consult the technical department at ORBINOX).

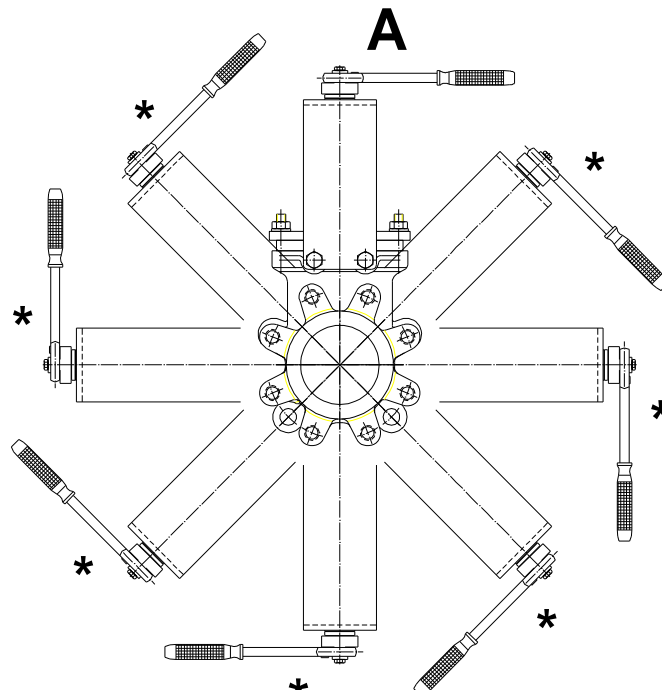

** For these positions please consult ORBINOX*

The installation of suitable supports is advised when significant vibrations coming from the piping are present.

Once the valve is installed, test that the flanges have been fastened correctly.

First, operate the valve with no flow in the tank. Then, test operation and valve seal with flow. It should be noted that the packing material might settle in shipping/storage, which can cause minor leakage. This can be remedied by tightening the gland follower (6) during installation. The nuts shall be tightened gradually until the leakage stops. Check that there is no metal contact between the gland follower (6) and the gate (2).

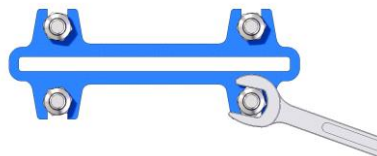

If the glandfollower nuts are pulled to hard, the force needed to operate the valve will increase, the valve function will be affected and the box packing lifetime will be shortened.

The maximum torque value for tightening the glandfollower nuts is 20N.m.

Once performance has been tested, the valve can be put into operation.

3. ACTUATORS

For EU Directives and other Certificates, please see the document: Directives & Certificates Compliance - Knife Gate Valves - IOM

3.1. WRENCH

To open the valve, turn the wrench (14) anticlockwise. To close, turn the wrench clockwise.

4. MAINTENANCE

For EU Directives and other Certificates, please see the document: Directives & Certificates Compliance - Knife Gate Valves - IOM

The valve must not undergo any modifications without a previous agreement with ORBINOX. ORBINOX shall not be liable for any damages that may arise due to the use of non original parts or components



To avoid personal injury or damage to property from the release of process fluid:

- Those in charge of handling and maintenance of the valve must be qualified and trained in valve operations.
- Use appropriate personal protection equipment (gloves, safety shoes, etc).
- Shut off all operating lines to the valve and place a warning sign.
- Isolate the valve completely from the process.
- Release process pressure.
- Drain the process fluid from the valve.

The only maintenance required is to change the gland packing (5) and the seal (3).

The life of these elements will depend on the working conditions of the valve such as: pressure, temperature, abrasion, chemical action, number of operations, etc.

4.1. Replacement of the gland packing (5):

1. Depressurise the circuit and place the valve in close position.
2. Release the stem nut (7) from the gate (2). (Photo 1)
3. Loosen the screws of the yoke (9) and remove it (without loosening the actuator).
4. Loosen the nuts of the gland follower (6) and remove it. (Photo 2).
5. Remove the old packing rings (5) and clean the stuffing box.



Photo 1



Photo 2

6. Insert the new packing rings (5), making sure that the ring joints alternate (the first on one side of the gate, the next on the other and so on).
7. Once the necessary packing rings (5) have been inserted, proceed with a steady initial tightening of the gland follower (6). (Photo 2).
8. Place the yoke (9) (with the actuator) and screw it.
9. Fix the stem nut (7) to the gate. (Photo 1)
10. Carry out some operations with a loaded circuit and then re-tighten the gland follower (6) to prevent leakage.

4.2. Replacement of the seal (3):

1. Remove the valve from the pipeline.
2. Remove the seal retainer K ring (4) which support the seal (3) loosening the screws that hold the K ring
3. Remove the worn seal (3) and clean the seal housing.
4. Insert the new seal (3) in the retainer ring (4).

If the valve has PTFE seal (3): first, place an O-ring (3') in the retainer ring (4) and later place the PTFE seal (3). (see the following detail).

EPDM / NBR / FKM-FPM

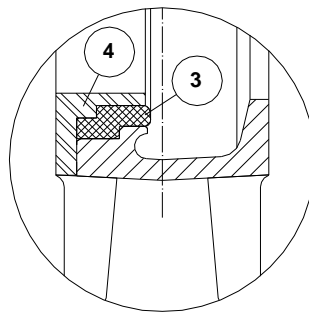

PTFE

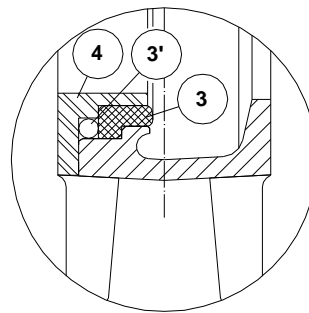

9. Insert the seal retainer ring (4) and the seal (3) altogether by hammering gently around the edge.
10. Remount the gate (2).
11. Once the necessary packing rings (5) have been inserted, proceed with a steady initial tightening of the gland follower (6). (Photo 2) following the steps of point 4.1.

4.3. Lubrication:

Lubricate the stem every 30 days with a calcium-based grease with the following characteristics: highly water resistant, low ash content, and excellent adherence.

5. STORAGE

- For long storage periods keep the valves indoors in a safe and dry place and protect it from any impact and or vibrations
- Storing temperatures: -10°C to +40°C
- Valves must be stored in either full open or full closed position
- For any component installed in the valves, electric motors, solenoid valves, etc, please refer to their own instructions manuals

6. ENVIRONMENTAL CONSIDERATIONS

- The packaging is made from environmentally friendly materials. Dispose of the packaging through the available recycling channels
- The valve is designed and manufactured with materials that can be recycled by specialised recycling firms. Once the life of the product is expired, you have to consider a proper disposal of the product in order to prevent any negative impact on the environment and allows for the recycling of valuable commodities
- Please follow the local environmental rules in your country for proper disposal

7. PARTS LIST & DRAWINGS

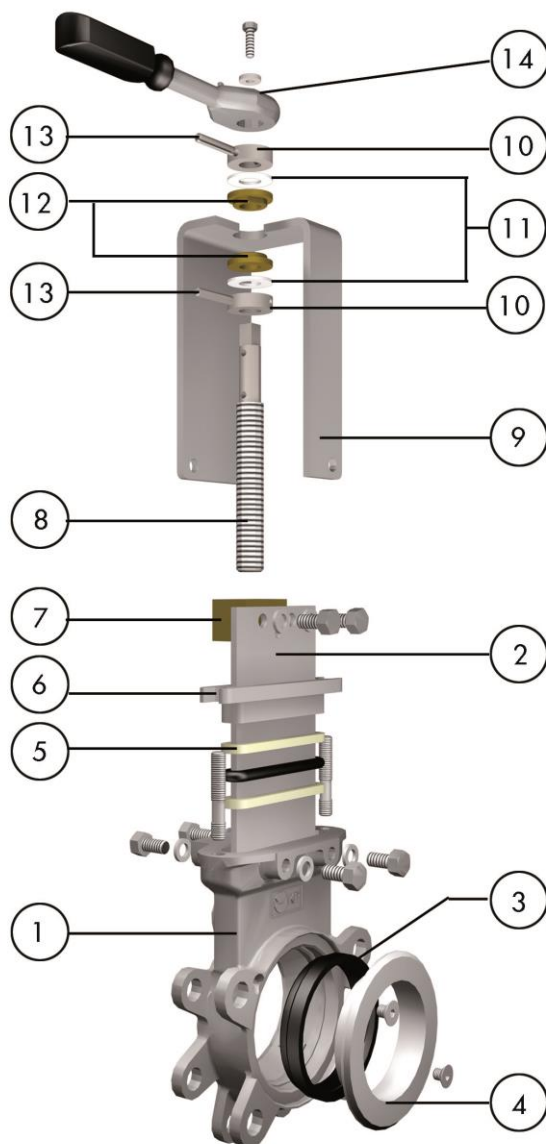

1. BODY	8. STEM
2. GATE	9. YOKE
3. SEAL	10. AXIAL FIXING BUSH
4. "K" RING	11. FRICTION WASHER
5. PACKING RING	12. BUSHING
6. GLAND FOLLOWER	13. SPRING PIN
7. STEM NUT	14. RATCHET WRENCH