

Model EX

WAFER STYLE KNIFE GATE VALVE

The EX model knife gate valve is an uni-directional wafer valve designed for general industrial service applications. The design of the body and seat assures non-clogging shut off on suspended solids in industries such as:

- Pulp and Paper
- Wastewater treatment plants
- Food and Beverage
- Mining
- Power plants
- Chemical plants
- Bulk handling
- Etc.

Sizes

DN 50 to DN 1200
Larger diameters on request

Working pressure and temperatures

DN 50 to DN 250: 10 bar
DN 300 to DN 400: 6 bar
DN 450: 5 bar
DN 500 to DN 600: 4 bar
DN 700 to DN 1200: 2 bar

GJL250 / GJS 400: -10°C / 80°C
CF8M: -20°C / 80°C

Standard flange drilling

EN-1092 PN10 / PN 16
ASME B16.5 (class 150)
Other flange drillings available on request

Directives

For EU Directives and other Certificates please see the document: Directives & Certificates Compliance - Knife Gate Valves –Catalogues and Datasheets

Testing

All valves are tested prior to shipping in accordance with the standard EN-12266-2



STANDARD PARTS LIST

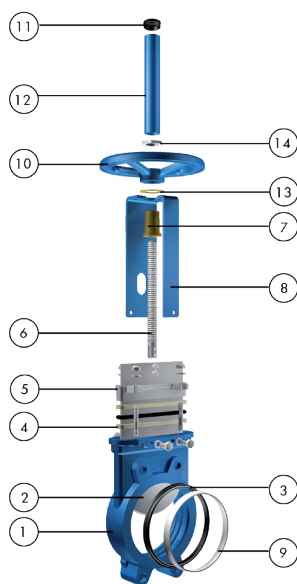

Part	Description
1	Body EN-GJL250 / EN-GJS400 / CF8M ¹
2	Gate AISI 304 / AISI 316 ¹
3	Seat Metal-Metal / EPDM / NBR
4	Packing PTFE Impreg. Synth. Fibre (With a EPDM O-Ring)
5	Gland follower Al. (DN 50-DN 300) / EN-GJS400 (DN 350-DN 1200) / CF8M ¹
6	Stem Stainless Steel
7	Stem nut Brass
8	Yoke Epoxy-coated Carbon Steel
9	"A" ring AISI 304 / AISI 316 ¹
10	Handwheel EN-GJS400
11	Cap Plastic
12	Stem protector Epoxy-coated Carbon Steel
13	Friction washer Brass
14	Nut Zinc Plated Carbon Steel

¹ Stainless steel configuration

DESIGN FEATURES

Body

Wafer style cast monoblock with raised faces and reinforcing ribs in large diameters for extra body strength. Internal cast-in gate wedges and guides allow for a tighter shut-off between gate and seat. Full port design for greater flow capacity and minimal pressure drop. The internal body design avoids any accumulation of solids that would prevent the valve from closing

Gate

Stainless steel gate. Gate is polished on both sides to avoid jamming and seat damage. Bottom of the gate edge is machined to a bevel to cut through solids for a tighter seal in the closed position. The thickness and/or material of the gate can be changed on request for higher pressure requirements

Seat (resilient)

Unique design that mechanically locks the seal in the internal of the valve body with a stainless steel retainer ring. Standard EPDM also available in different materials such as Viton, PTFE, etc.

Packing

Long-life packing with several layers of braided fibre plus an EPDM o-ring, with an easy access packing gland ensuring a tight seal. Long-life braided packing is available in a wide range of materials

Stem

The standard stainless steel with DIN 103 trapezoidal thread stem offers a long corrosion resistant life. For rising stem handwheel actuators only, a stem protector is provided for additional protection against dust while the valve is in the open position

Yoke or actuator support

Made of epoxy coated steel (stainless steel available on request). Compact design makes it extremely robust even under the most severe conditions

Epoxy coating

The epoxy coating on all ORBINOX cast iron and carbon steel valve bodies and components is applied by means of an electrostatic process, making the valves corrosion-resistant with a high quality finished surface. The ORBINOX standard colour is RAL-5015 blue

Gate safety protection

ORBINOX automated valves are provided with gate guards in accordance with EU Safety Standards. The design feature prevents any objects from being caught accidentally while the gate is moving

Actuators

ORBINOX offers a complete range of actuator solutions, including manual, pneumatic, electric and hydraulic actuators

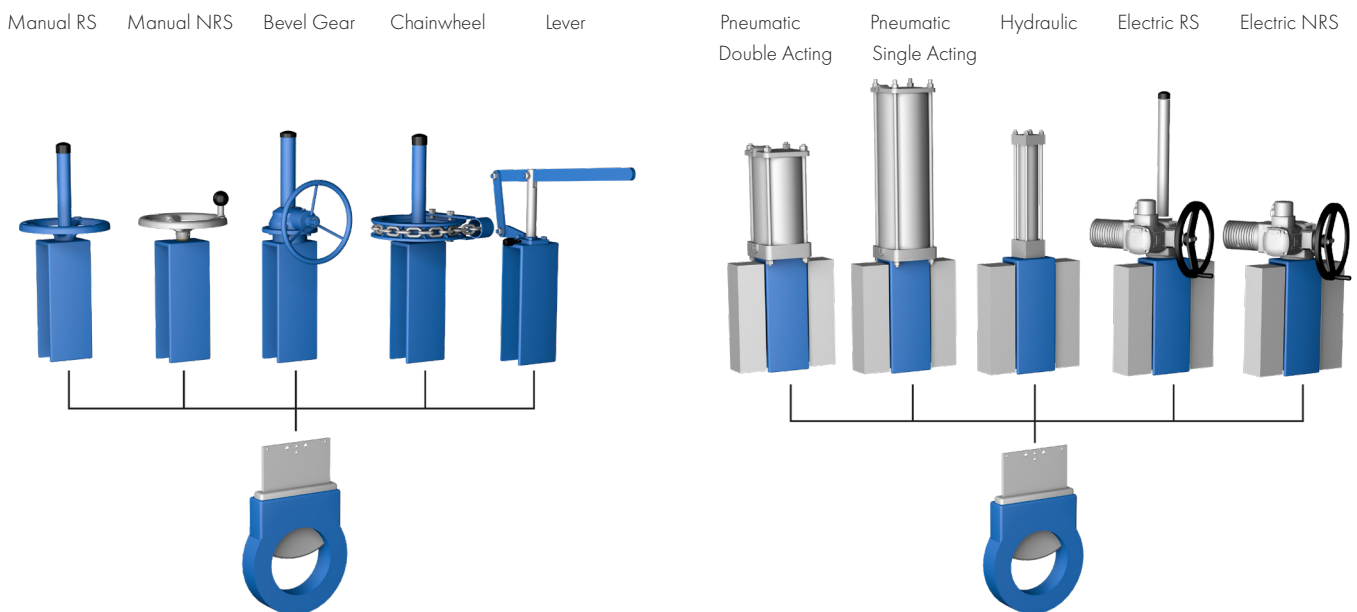

OTHER OPTIONS

Other materials of construction

Ductile iron, carbon steel, special stainless steels (Duplex, ...), special alloys (254SMO, Hastelloys, ...), etc.

Fabricated valves

ORBINOX designs, produces and delivers special fabricated valves for special process conditions (big sizes and/or high pressures)

Surface treatments

Valve components can be protected or coated for a longer life expectancy, depending on the application of the valves and the valve service conditions. At ORBINOX we can offer alternative treatments and coatings for the different valve components to improve their properties against abrasion (Stellite, hard-chroming, carbides, ...), against corrosion and against adherence

Bonnet (Fig. 1)

Assures tight sealing to atmosphere. Reduces packing maintenance



Fig.1



Fig.2

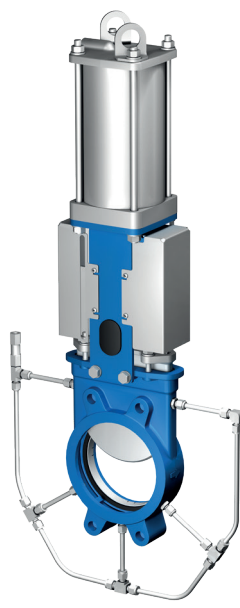

Fig.3



Fig.4



Fig.5

V-Port (Fig. 2)

60 degree and pentagonal port design. Selection depends on the desired fluid control type

Locking device (Fig. 2)

The valve can be designed with a locking pin system to block the gate in emergency situations or for maintenance operations

Flush ports (Fig. 3)

Allow for cleaning of solids trapped within the body cavities that can obstruct the flow or prevent the valve from closing. Depending on the process, purging can be made with air, steam, liquids, etc.

Mechanical stops

Mechanical stops can be added to limit stem travel at a certain stroke position

Actuator manual override (Fig. 4)

Pneumatic and electric actuators can be equipped with manual override handwheels to manually operate the actuators in emergency situations or for maintenance operations

Stem extensions and floor stand (Fig. 5)

Extensions for valve operation when valves are installed in positions below operation level are available, including wall brackets and different types of pedestals for actuators

Accessories for pneumatic valve automation

Limit and proximity switches, solenoid valves, positioners, flow regulations, air filter units, silencers, junction boxes

SEAT/SEAL TYPES

Material	Max.T (°C)	Applications
Metal/Metal	>250	High temp./Low tightness
EPDM (E)	120	Acids and non mineral oils
NBR (N)	120	Resistance to petroleum products
FKM-FPM (V)	200	Chemical service / High temp.
VMQ (S)	250	Food service / High temp.
PTFE (T)	250	High corrosion

More details and other materials under request

PACKING TYPES

Material	Max.T (°C)	pH
PTFE impregn. synth. fibre (ST)	250	2-13
Braided PTFE (TH)	260	0-14
Graphited (GR)	600	0-14
Ceramic fibre (FC)	1200	

All types include an elastomere O-ring (same material as seat), excluding TH, GR and FC

SEAT CONFIGURATIONS/DESIGNS

Type	Features	
Metal / Metal	<ul style="list-style-type: none"> - High temperature applications - High density media applications - When full tightness is not required 	
A Ring Resilient	<ul style="list-style-type: none"> - Standard resilient seat - See temperature chart for seat materials - Seat with replaceable ring 	
B Ring Resilient	<ul style="list-style-type: none"> - Reinforced resilient seat design - See temperature chart for seat materials - Seat with replaceable retainer ring - Ring available in different materials: AISI 316, Ni Hard,... 	
B Ring Metal / Metal	<ul style="list-style-type: none"> - High temperature applications - High density media applications - When full tightness is not required - Replaceable ring 	

OTHER SEAT FEATURES

Type	Features	
Deflection cone C	<ul style="list-style-type: none"> - Used to protect valve seats and internals - Material: AISI 316, Ni-Hard, etc. - Face-to-face dimension increases: <ul style="list-style-type: none"> DN 50 to DN 250, X = 9mm DN 300 to DN 600, X = 12mm - Larger diameters on request 	

HANDWHEEL RISING STEM

Standard manual actuator available from DN 50 to DN 1000 and recommended with gearbox from DN 300 and above

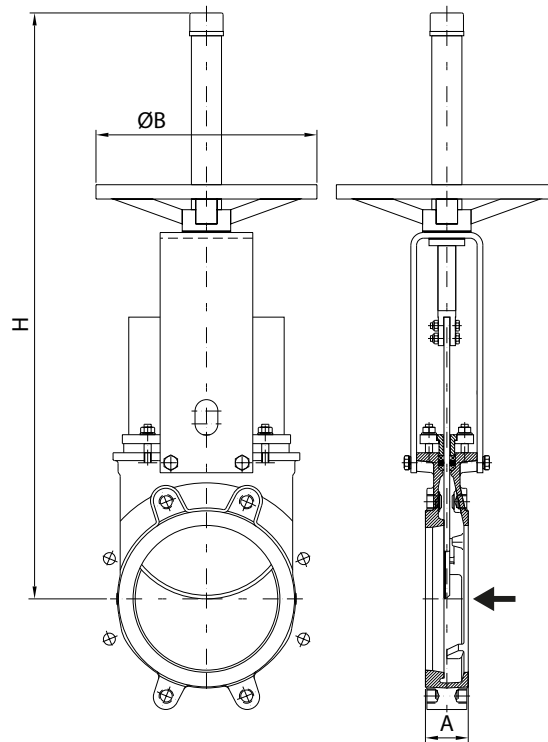

DN	A	ØB	H	Weight (Kg.)
50	40	225	420	11
65	40	225	450	12
80	50	225	475	13
100	50	225	520	14
125	50	225	600	17
150	60	225	652	21
200	60	310	822	34
250	70	310	1022	46
300	70	310	1122	64
350	96	410	1323	94
400	100	410	1427	125
450	106	550	1594	162
500	110	550	1707	200
600	110	550	2022	286
700	110	800	2778	405
750	110	800	2900	455
800	110	800	2980	512
900	110	800	3215	680
1000	110	800	3400	865

HANDWHEEL NON-RISING STEM

Manual actuator recommended for installation where space is limited, available from DN 50 to DN 1000 and recommended with gearbox from DN 350 and above.

Aluminium handwheel for DN 50 to DN 300 valves and EN-GJS400 from DN 350 and above

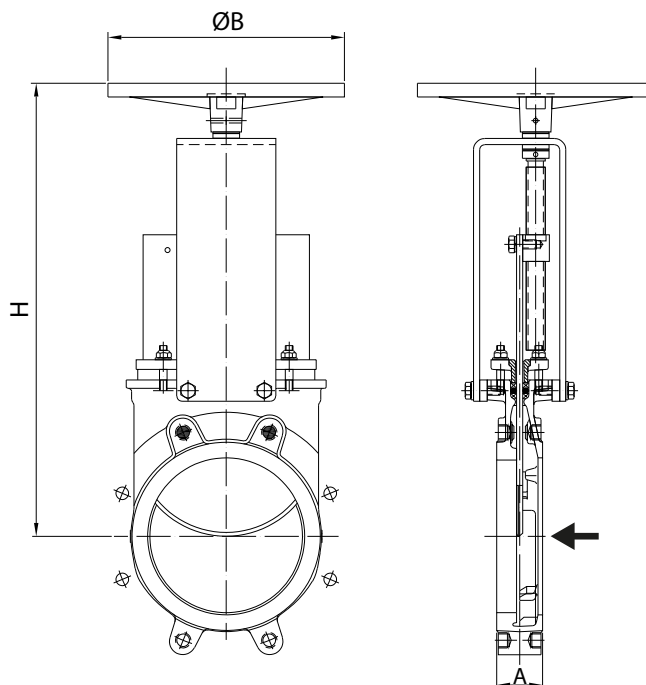

DN	A	ØB	H	Weight (Kg.)
50	40	225	312	10
65	40	225	339	11
80	50	225	364	12
100	50	225	405	13
125	50	225	439	15
150	60	225	490	18
200	60	310	595	32
250	70	310	695	45
300	70	310	795	60
350	96	410	945	93
400	100	410	1049	126
450	106	550	1141	179
500	110	550	1254	207
600	110	550	1459	279
700	110	800	1737	-
750	110	800	1856	-
800	110	800	1939	-
900	110	800	2174	-
1000	110	800	2381	-

BEVEL GEAR

Manual actuator recommended for valves larger than DN 300. Available both for rising stem and non-rising stem configurations and with different reduction ratios

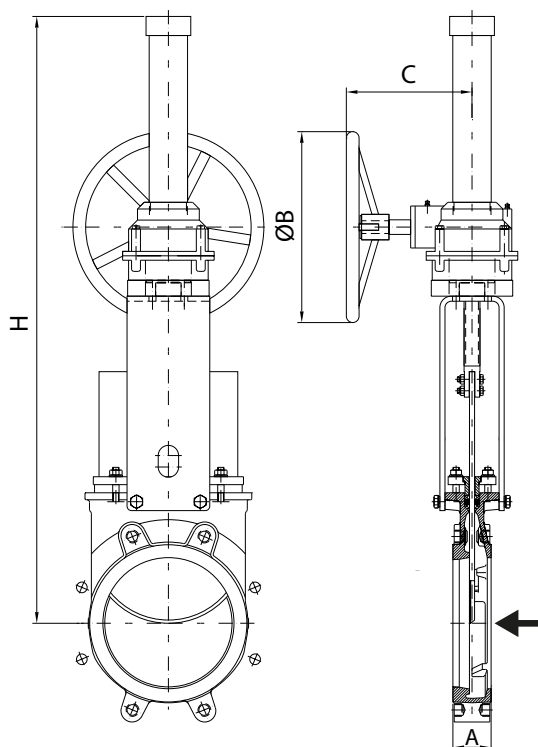

DN	A	ØB	H	C	Weight (Kg.)
200	60	300	994	200	50
250	70	300	1094	200	64
300	70	300	1194	200	78
350	96	450	1657	262	114
400	100	450	1761	262	140
450	106	450	1853	262	173
500	110	450	1966	262	220
600	110	450	2171	262	296
700	110	450	2423	262	-
750	110	450	2555	262	-
800	110	650	2926	260	-
900	110	650	3160	288	-
1000	110	650	3342	288	-
1200	150	850	3935	365	-

CHAINWHEEL

Manual actuator recommended for elevated installations. The handwheel is replaced by a chainwheel to accommodate the chain. Available both for rising stem and non-rising stem and for sizes from DN 50 to DN 600

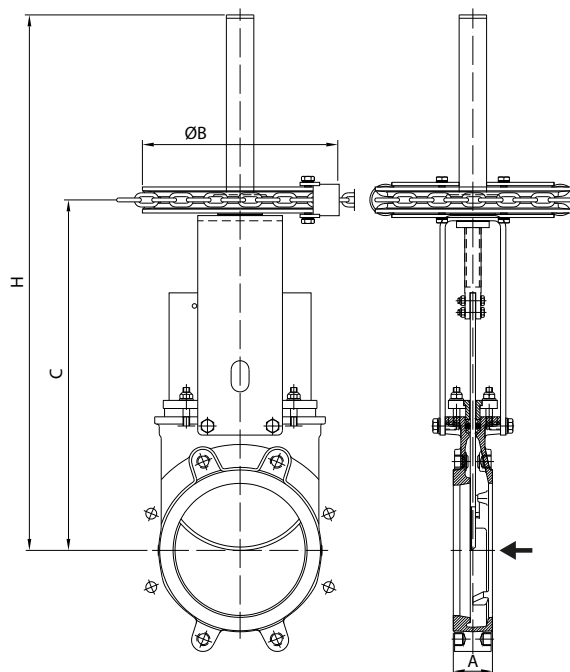

DN	A	ØB	C	H	Weight (Kg.)
50	40	225	253	420	14
65	40	225	280	450	15
80	50	225	305	475	16
100	50	225	347	520	18
125	50	225	380	600	20
150	60	225	431	652	24
200	60	300	538	822	39
250	70	300	638	1022	53
300	70	300	738	1122	69
350	96	454	856	1323	106
400	100	454	960	1427	132
450	106	454	1052	1594	175
500	110	454	1165	1707	217
600	110	454	1370	2022	293

LEVER

Manual actuator recommended for quick opening and closing, available from DN 50 to DN 200

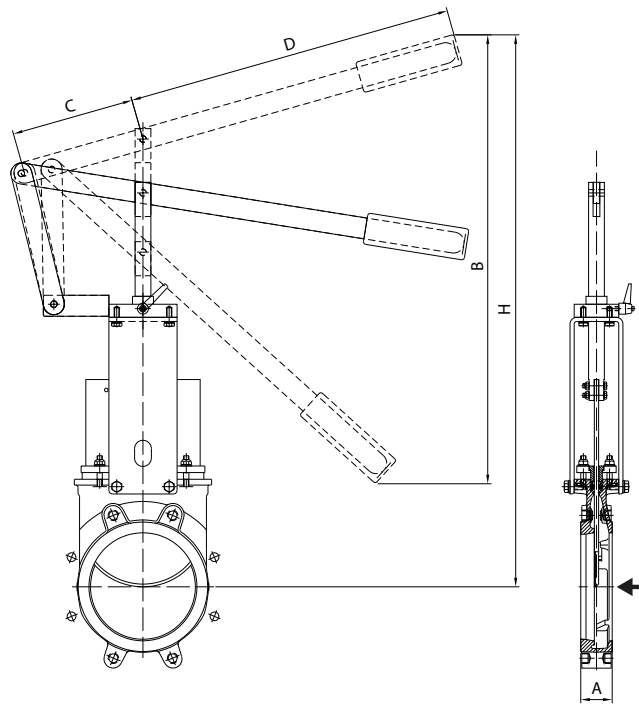

DN	A	B	C	D	H	Weight (Kg.)
50	40	256	150	315	408	11
65	40	259	150	315	435	12
80	50	307	150	315	509	14
100	50	439	150	415	637	15
125	50	529	150	415	755	17
150	60	620	150	415	895	19
200	60	822	235	620	1038	37

PNEUMATIC CYLINDER

With a double-acting pneumatic cylinder as standard, it is available in sizes from DN 50 to DN 1000. Single-acting pneumatic cylinders, manual overrides, fail-safe systems as well as a wide variety of pneumatic accessories for valve automation available. Actuator sized for 6 bar air supply, see ORBINOX Pneumatic Solutions Catalogue for more information.

For valves installed in a horizontal position, actuator supports to plant structure is recommended

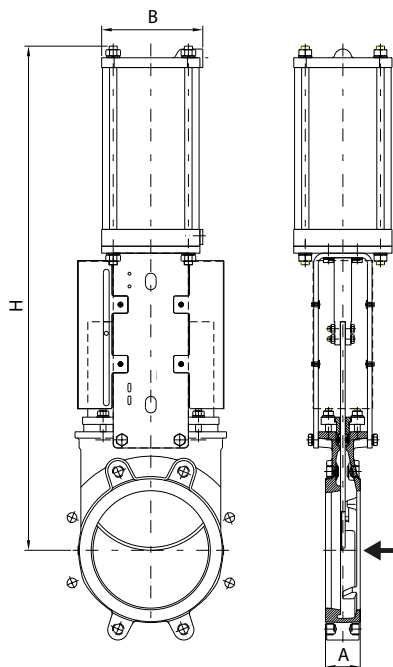

DN	A	B	H	Connect.	Weight (Kg.)
50	40	115	412	1/4 "G	10
65	40	115	454	1/4 "G	12
80	50	115	497	1/4 "G	13
100	50	115	558	1/4 "G	15
125	50	140	632	1/4 "G	21
150	60	140	708	1/4 "G	25
200	60	175	872	1/4 "G	41
250	70	220	1042	3/8" G	60
300	70	220	1192	3/8" G	75
350	96	277	1387	3/8" G	128
400	100	277	1541	3/8" G	156
450	106	382	1710	1/2" G	234
500	110	382	1873	1/2" G	267
600	110	382	2178	1/2" G	334
700	110	444	2546	3/4" G	520
750	110	444	2725	3/4" G	585
800	110	444	2850	3/4" G	650
900	110	515	3202	3/4" G	850
1000	110	515	3488	3/4" G	1060

ELECTRIC ACTUATOR

Designed with a yoke flange for the actuator according to ISO 5210 / DIN 3338 as standard, it is available from DN 50 to DN 1200, both for rising stem and non-rising stem configurations and with manual overrides.

Knife gate valves with a wide range of electric actuator brands available.

For valves installed in a horizontal position, actuator supports to plant structure is recommended

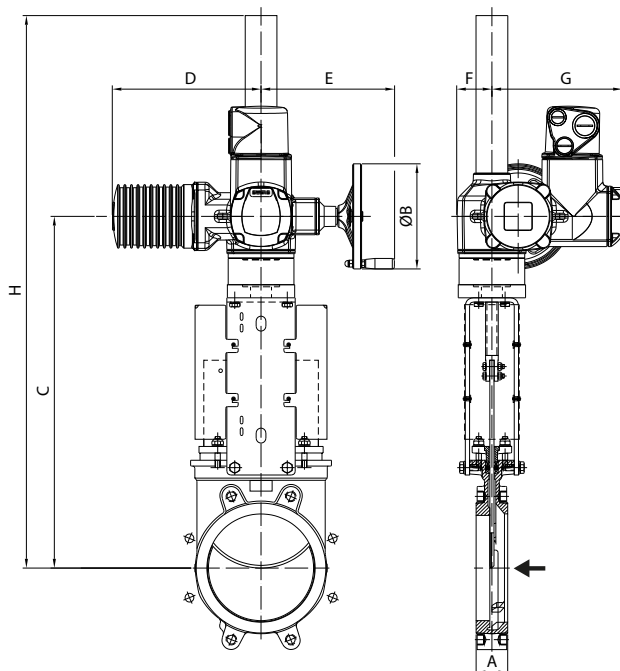

DN	A	C	ØB	H	D	E	F	G	Torque (Nm)	Weight (Kg.)
50	40	377	160	547	265	249	62	238	10	68
65	40	404	160	574	265	249	62	238	10	69
80	50	429	160	599	265	249	62	238	10	70
100	50	470	160	640	265	249	62	238	10	72
125	50	504	160	674	265	249	62	238	15	74
150	60	555	160	1055	265	249	62	238	20	78
200	60	669	160	1169	265	249	62	238	30	89
250	70	769	160	1269	265	249	62	238	45	102
300	70	869	160	1369	265	249	62	238	40	120
350	96	940	200	1440	283	254	65	248	70	126
400	100	1044	200	1544	283	254	65	248	90	143
450	106	1172	200	1672	283	254	65	248	110	190
500	110	1280	200	1780	283	254	65	248	95	232
600	110	1565	315	2065	389	336	91	286	140	336
700	110	1763	315	2846	389	336	91	285	120	-
750	110	1882	315	2965	389	336	91	286	140	-
800	110	1948	315	3031	389	336	91	286	180	-
900	110	2157	400	3240	389	339	91	286	220	-
1000	110	2350	400	3431	389	339	91	286	300	-
1200	150	2732	500	4137	430	365	117	303	480	-

FLANGE AND BOLTING DETAILS EN-1092 PN10

DN	K	n°	M	T	
50	125	4	M-16	11	4 - 0 - 0
65*	145	4	M-16	11	4 - 0 - 0
80	160	8	M-16	11	4 - 0 - 4
100	180	8	M-16	11	4 - 0 - 4
125	210	8	M-16	11	4 - 0 - 4
150	240	8	M-20	14	4 - 0 - 4
200	295	8	M-20	14	4 - 0 - 4
250	350	12	M-20	18	6 - 0 - 6
300	400	12	M-20	18	6 - 0 - 6
350	460	16	M-20	22	6 - 4 - 6
400	515	16	M-24	24	6 - 4 - 6
450	565	20	M-24	24	8 - 6 - 6
500	620	20	M-24	24	8 - 6 - 6
600	725	20	M-27	24	8 - 6 - 6
700	840	24	M-27	20	10 - 6 - 8
800	950	24	M-30	20	10 - 6 - 8
900	1050	28	M-30	20	12 - 8 - 8
1000	1160	28	M-33	20	12 - 8 - 8
1200	1380	32	M-36	30	22 - 6 - 4

* Flange drilling of DN 65 PN10/16 according to EN-1092 allow 4 or 8 drills. ORBINOX designs of DN 65 PN10/16 have 4 drills

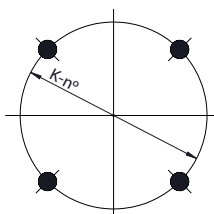

DN 50-65

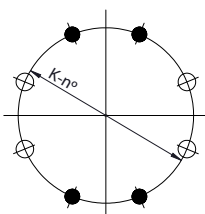

DN 80-200

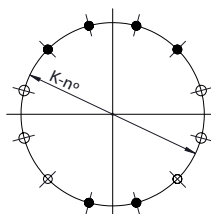

DN 250-300

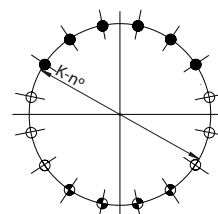

DN 350-400

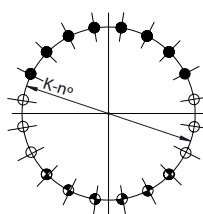

DN 450-600

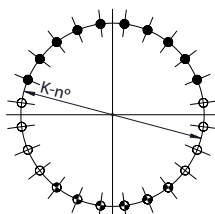

DN 700-800

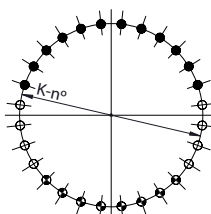

DN 900-1000

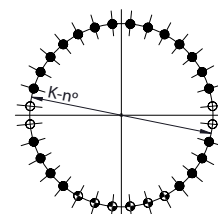

DN 1200

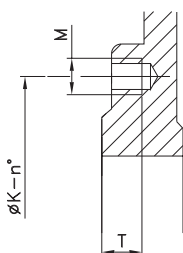

- BLIND TAPPED HOLES
- TAPPED THROUGH
- THROUGHGOING BOLTS

FLANGE AND BOLTING DETAILS ASME B16.5, CLASS 150*

DN	K	n°	M	T	
2"	4 3/4"	4	5/8" - 11 UNC	3/8"	4 - 0 - 0
2 1/2"	5 1/2"	4	5/8" - 11 UNC	3/8"	4 - 0 - 0
3"	6"	4	5/8" - 11 UNC	3/8"	4 - 0 - 0
4"	7 1/2"	8	5/8" - 11 UNC	3/8"	4 - 0 - 4
5"	8 1/2"	8	3/4" - 10 UNC	3/8"	4 - 0 - 4
6"	9 1/2"	8	3/4" - 10 UNC	1/2"	4 - 0 - 4
8"	11 3/4"	8	3/4" - 10 UNC	1/2"	4 - 0 - 4
10"	14 1/4"	12	7/8" - 9 UNC	3/4"	6 - 0 - 6
12"	17"	12	7/8" - 9 UNC	3/4"	6 - 0 - 6
14"	18 3/4"	12	1" - 8 UNC	7/8"	4 - 4 - 4
16"	21 1/4"	16	1" - 8 UNC	1"	6 - 4 - 6
18"	22 3/4"	16	1 1/8" - 7 UNC	1"	6 - 4 - 6
20"	25"	20	1 1/8" - 7 UNC	1"	8 - 6 - 6
24"	29 1/2"	20	1 1/4" - 7 UNC	1"	8 - 6 - 6
28"	34"	28	1 1/4" - 7 UNC	3/4"	12 - 6 - 10
30"	36"	28	1 1/4" - 7 UNC	3/4"	12 - 8 - 8
32"	38 1/2"	28	1 1/2" - 6 UNC	3/4"	12 - 8 - 8
36"	42 3/4"	32	1 1/2" - 6 UNC	3/4"	14 - 8 - 10
40"	47 1/4"	36	1 1/2" - 6 UNC	3/4"	14 - 12 - 10
42"	49 1/2"	36	1 1/2" - 6 UNC	3/4"	14 - 12 - 10
48"	56"	44	1 1/2" - 6 UNC	13/16"	26 - 10 - 8

* From NPS 24, acc. to ASME B16.47 Series A (class 150)

